

# Determination of dissolved gas concentrations in natural waters using an in-situ, membrane inlet mass spectrometer

**Fifth Workshop on Harsh  
Environment Mass Spectrometry**

**September 20-23, 2005  
Lido Beach, Sarasota, Florida**

# Contents

- Instrument Design and Function
- Recent Deployments
- Calibration
- New Instrument Development
- Summary



# Instrument Design and Function

# Underwater Mass Spectrometry at USF



<b>Type</b>	<b>Linear quadrupole mass filter</b>
<b>Mass Range</b>	<b>200 amu</b>
<b>Inlet System</b>	<b>Membrane Introduction</b>
<b>Power Consumption</b>	<b>88 Watts</b>
<b>Supply Voltage</b>	<b>24 VDC or 110 VAC</b>
<b>Deployment Time</b>	<b>Configuration dependent</b>
<b>Dimensions</b>	<b>Ø 19 cm (7.5")</b>
	<b>L 105 cm (41")</b>
<b>Weight</b>	<b>33 kg (72.7 Lbs.)</b>
<b>Depth</b>	<b>&gt;1000 m</b>
<b>Real-time tether range</b>	<b>~1600 m (1 mile)</b>

# USF Underwater Mass Spectrometer

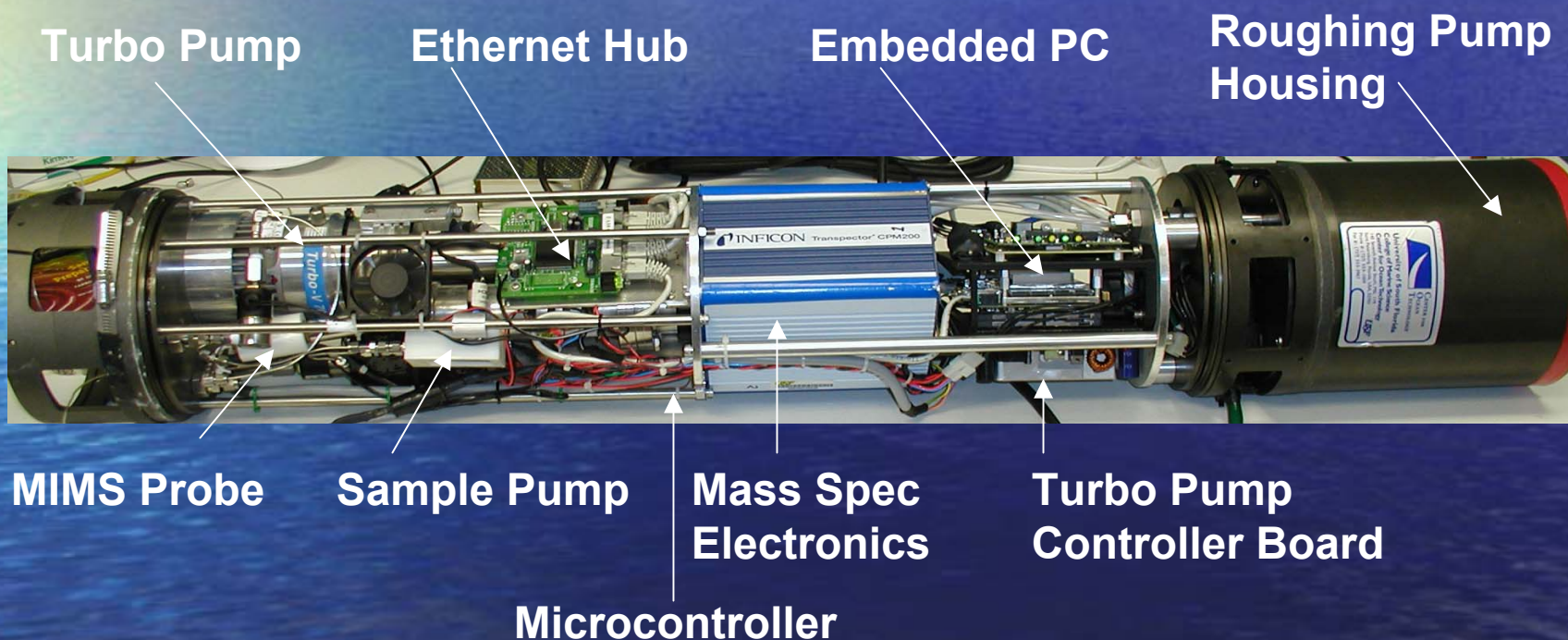

# High Pressure Membrane Inlet

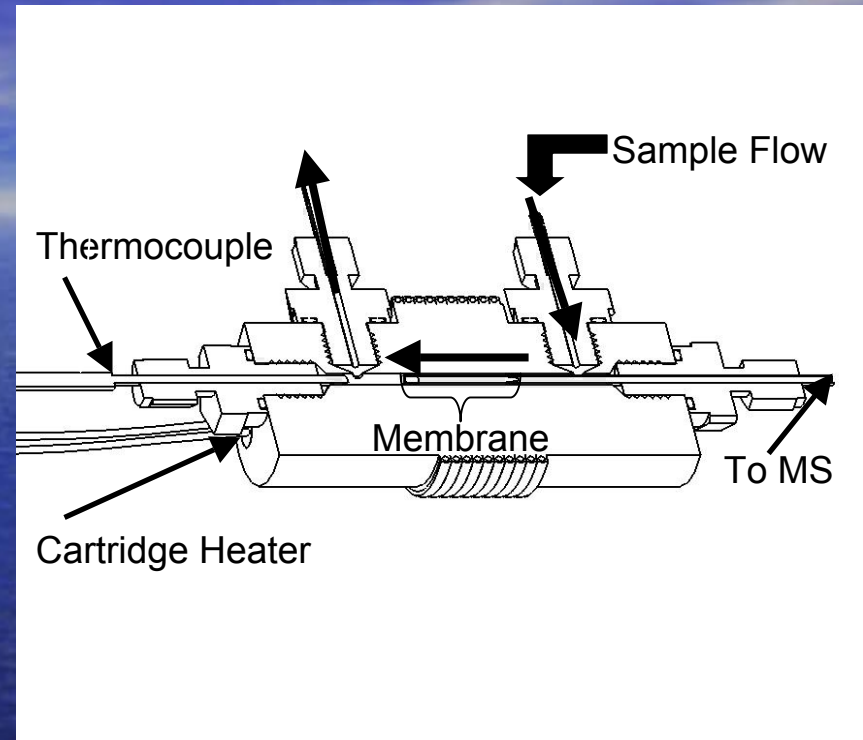
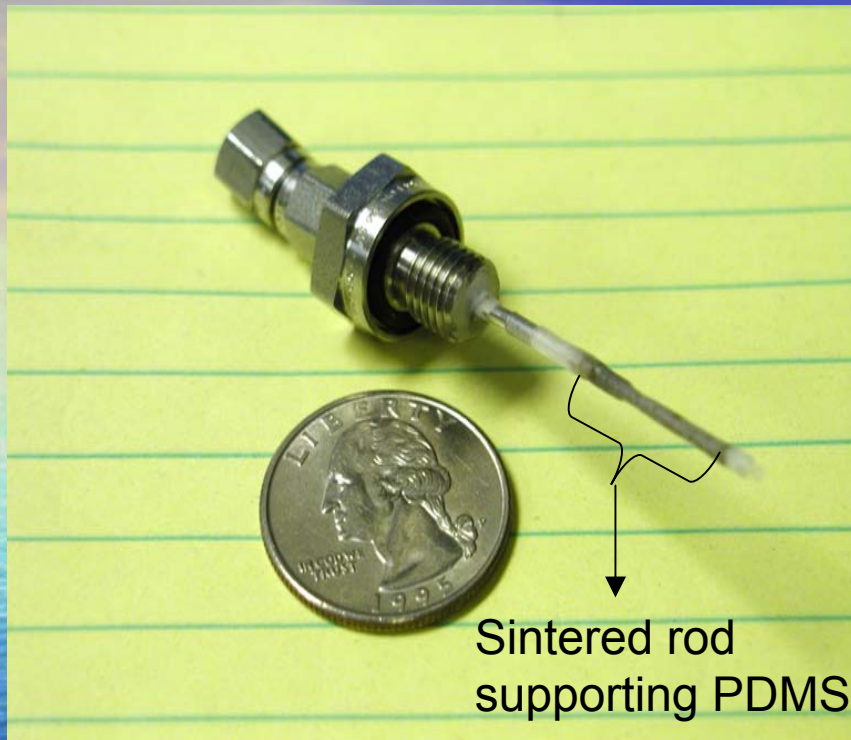

- **PDMS membrane permeable to low molecular weight, non-polar compounds**
- **Membrane supported by machined 1/16" sintered Hastelloy rod**
- **Inserted thermocouple allows for direct measurement of sample temperature**
- **Sample flow-over configuration**

# Flow-through Membrane Inlet



- **Brass probe based on original Scott Bauer design from MIMS Technology, Inc.**
- **Sample flow-through configuration**
- **Successfully deployed to 30 meters depth**
- **Greater response observed for flow-through inlet <sup>1</sup>**
- **Attempt to develop high-pressure version of this inlet**

<sup>1</sup>LaPack, M.A., The Theory and Practice of Membrane Extractions, PhD Dissertation, 1994.

# Target Analytes for Underwater MIMS

- Volatile Organic Compounds  
Benzene, Toluene, Xylene, Dimethyl sulfide, etc.  
*(very low ppb, ~1-5 min response)*
- Gases  
CH<sub>4</sub>, N<sub>2</sub>, O<sub>2</sub>, CO<sub>2</sub>, Ar, etc.  
*(very low ppm, ~10 sec response)*
- Semi-Volatile Compounds  
Naphthalene, PAHs, Pesticides, etc.  
*(low ppb, ~5-20 min response)*



# Recent Deployments

# Saanich Inlet Deployment

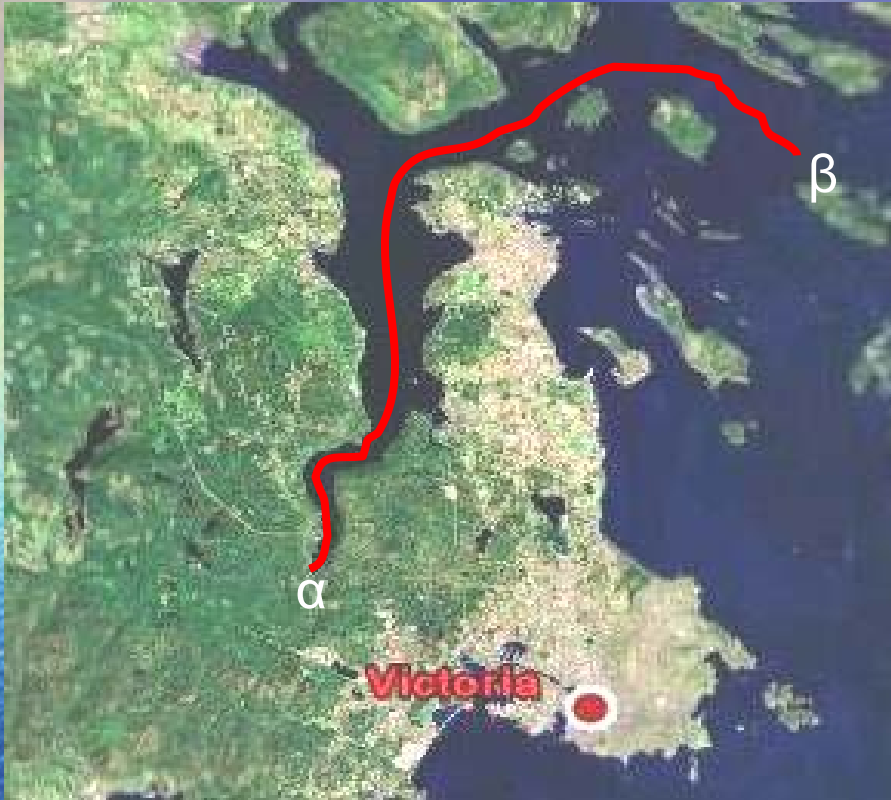

- The inlet is located just north of Victoria, BC
- Maximum Depth: 225 meters
- There is a ledge at 70 m located at the northern mouth of the inlet
- The ledge restricts bottom water circulation and turnover
- Bottom waters are anoxic with the presence of reduced species, ie.  $\text{CH}_4$ ,  $\text{H}_2\text{S}$

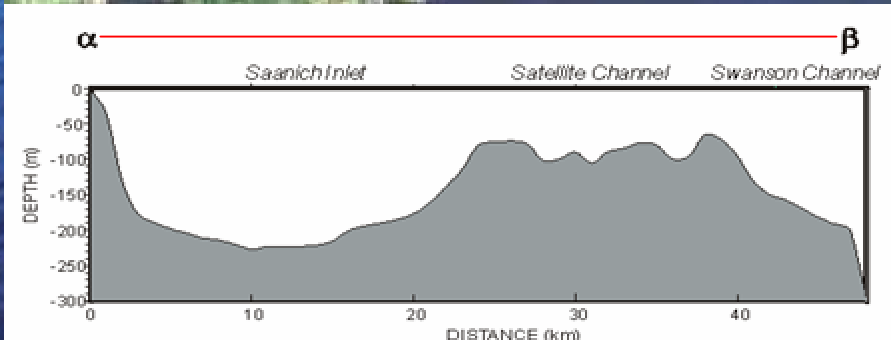

# Saanich Inlet Time Series

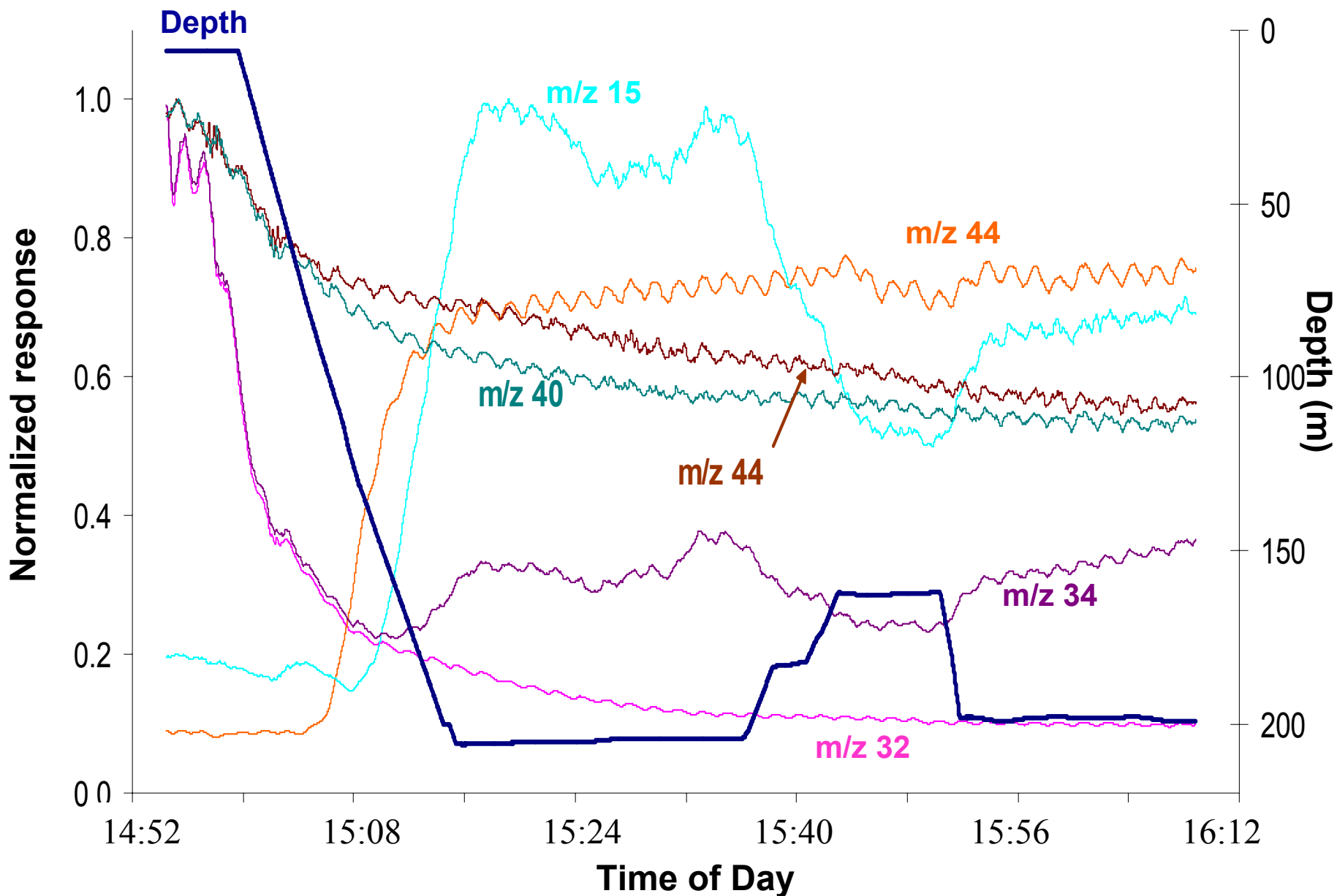

# Saanich Inlet Depth Profiles

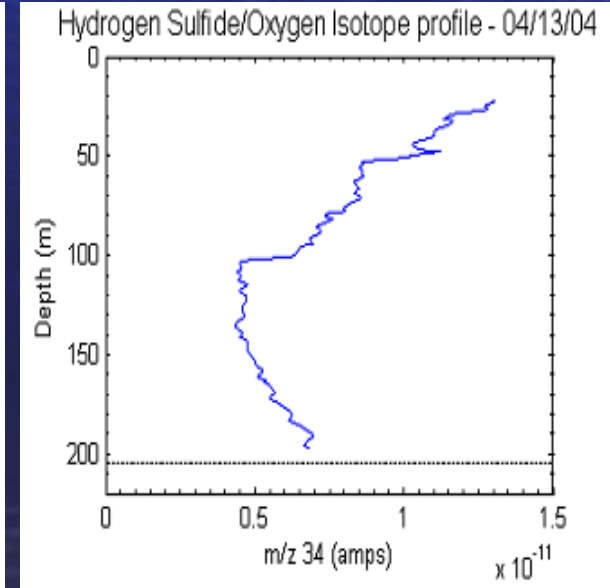
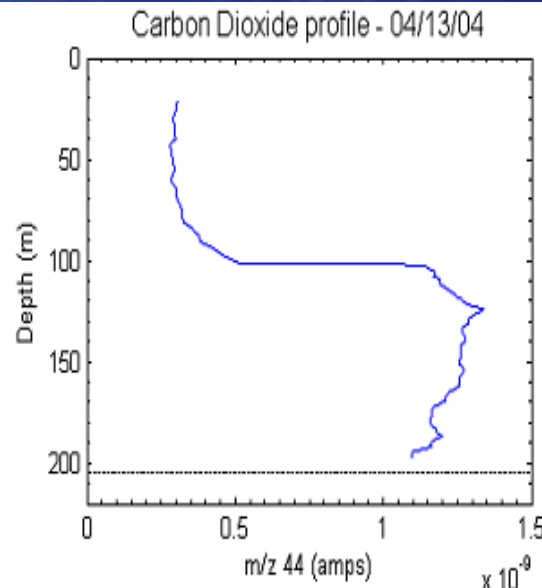
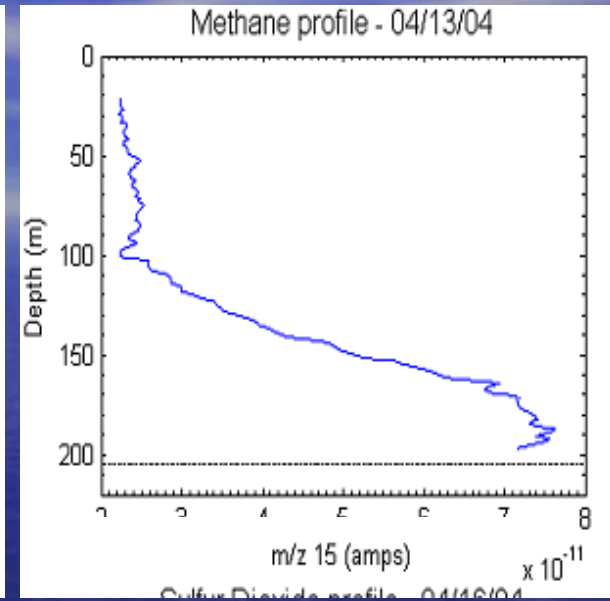
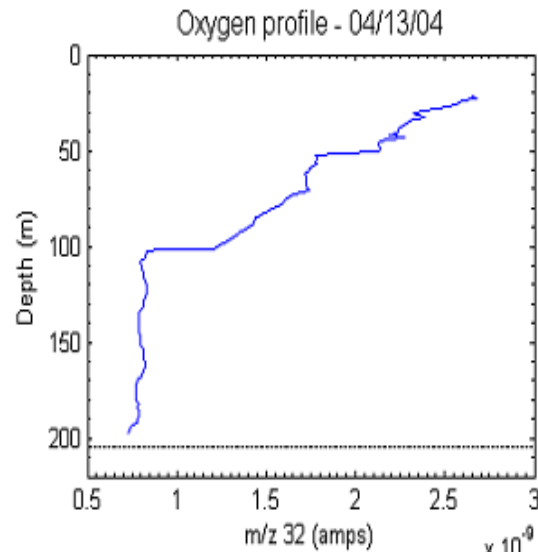
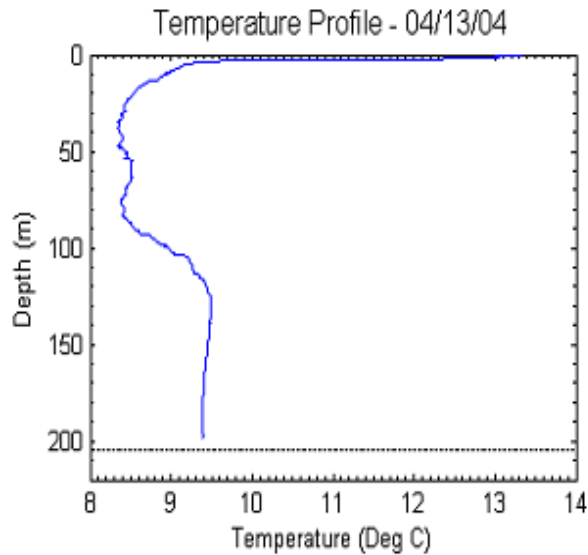

- Sharp increase m/z 44, 15
- Sharp decrease m/z 32
- Chemocline @ 100 m

# Gulf of Mexico Cruise, April 2005



- Vertical profile with mass spec to 500 m depth
- Mount instrument on shipboard rosette
- Communicate with instrument through standard UNOLS CTD tether to which rosette is attached
- Determine dissolved gas concentrations from mass spec data with the aid of a portable calibration unit

# Calibration - Method

- Two solutions with known but different gas concentrations are mixed at various ratios to allow for intermediate concentrations and *automated* calibration

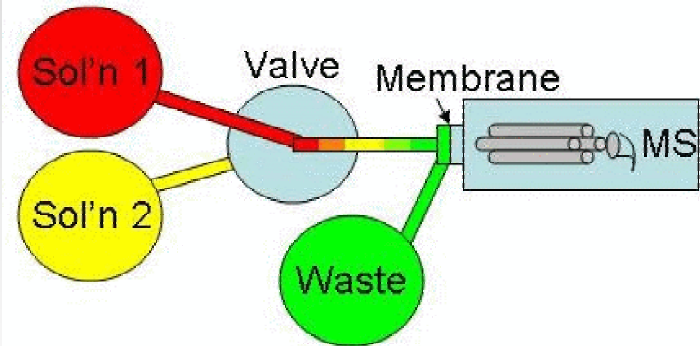

- Shipboard apparatus allows in-field sample preparation and calibration

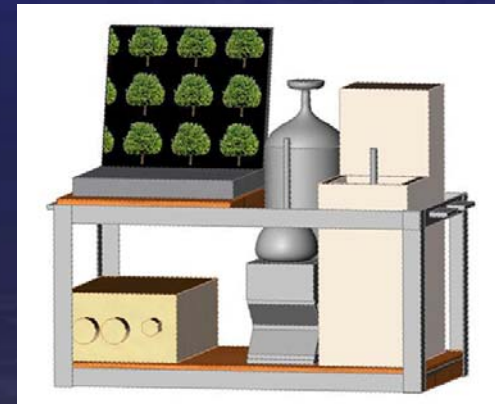

# Gulf of Mexico, April 26 2005, Cast 1, m/z 40

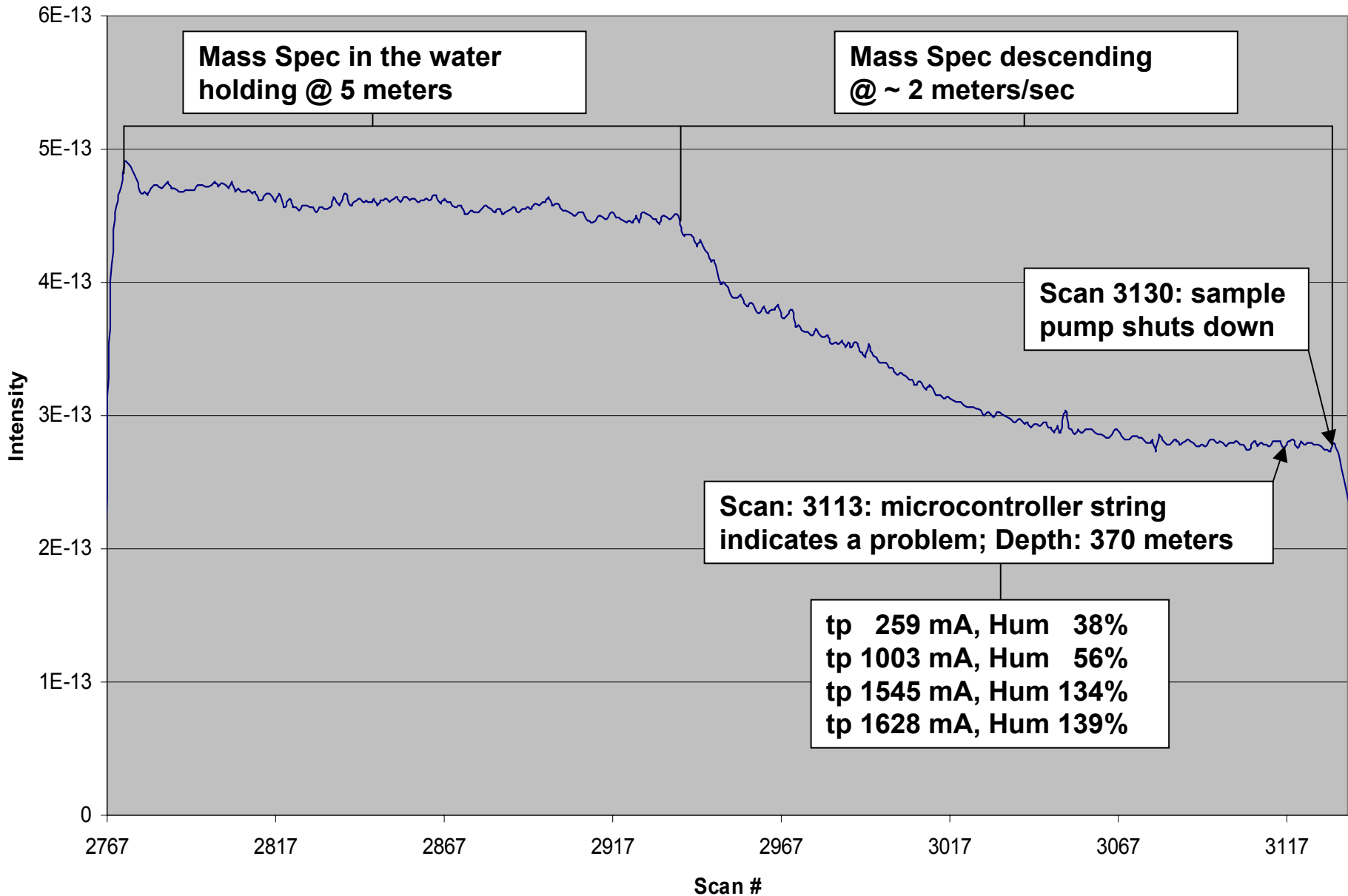

# Sample flow integrated thermocouples

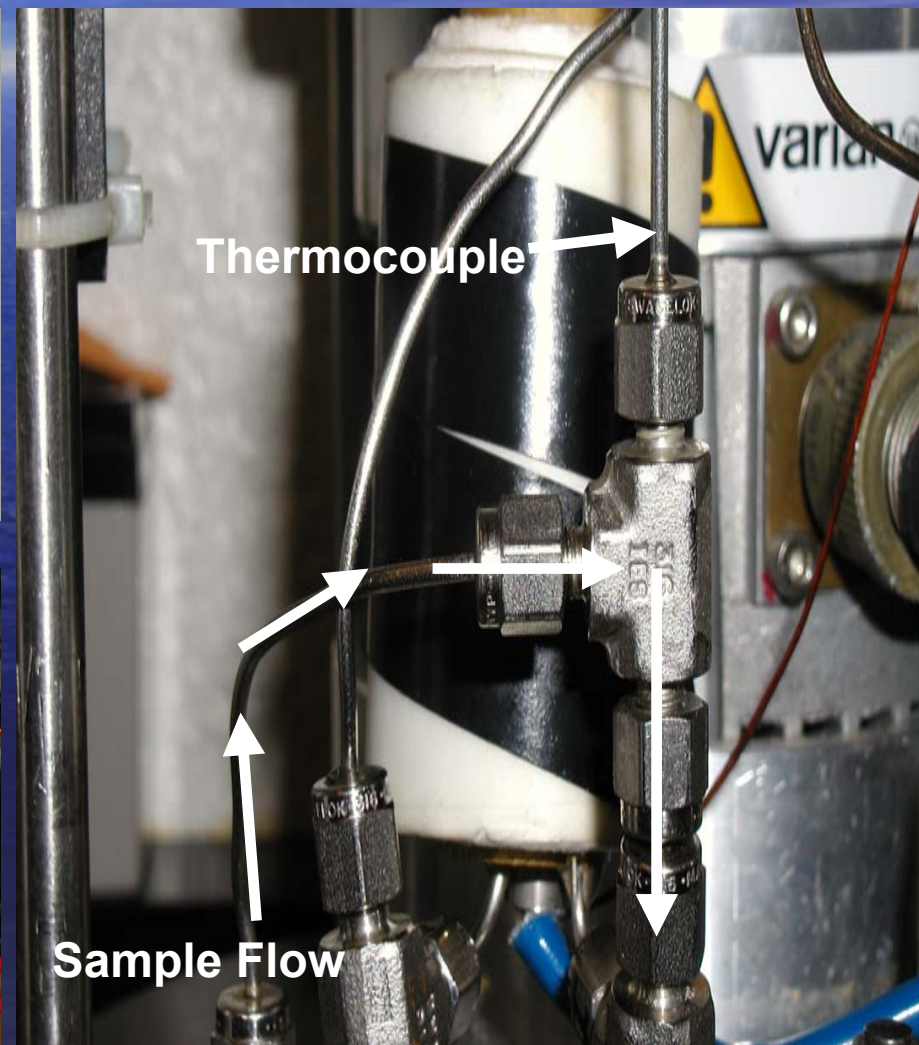
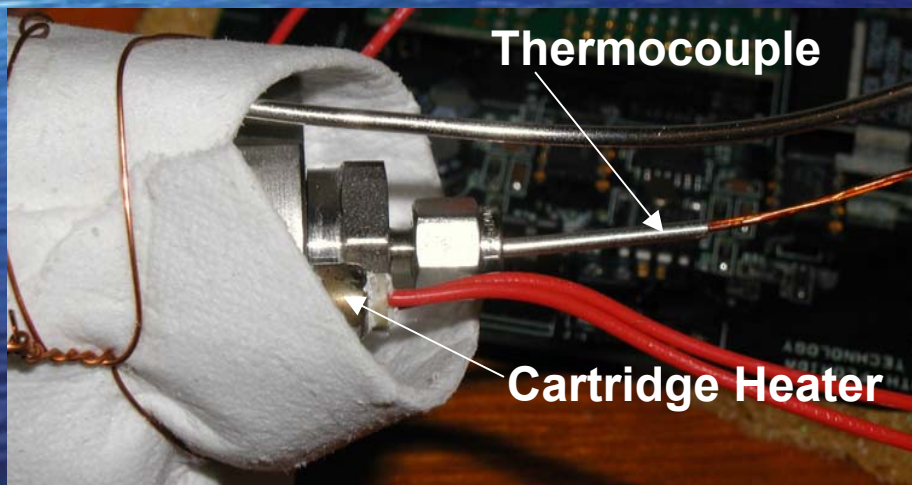
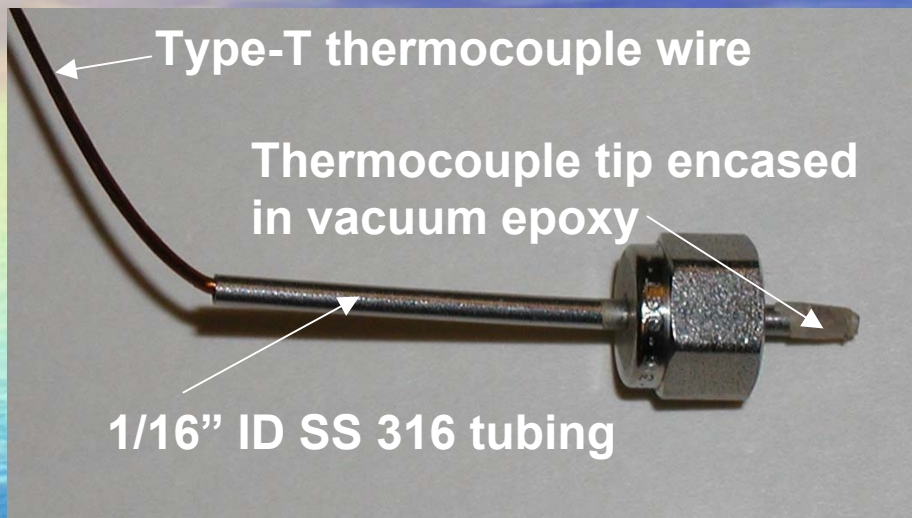

# Thermocouple/microcontroller connection

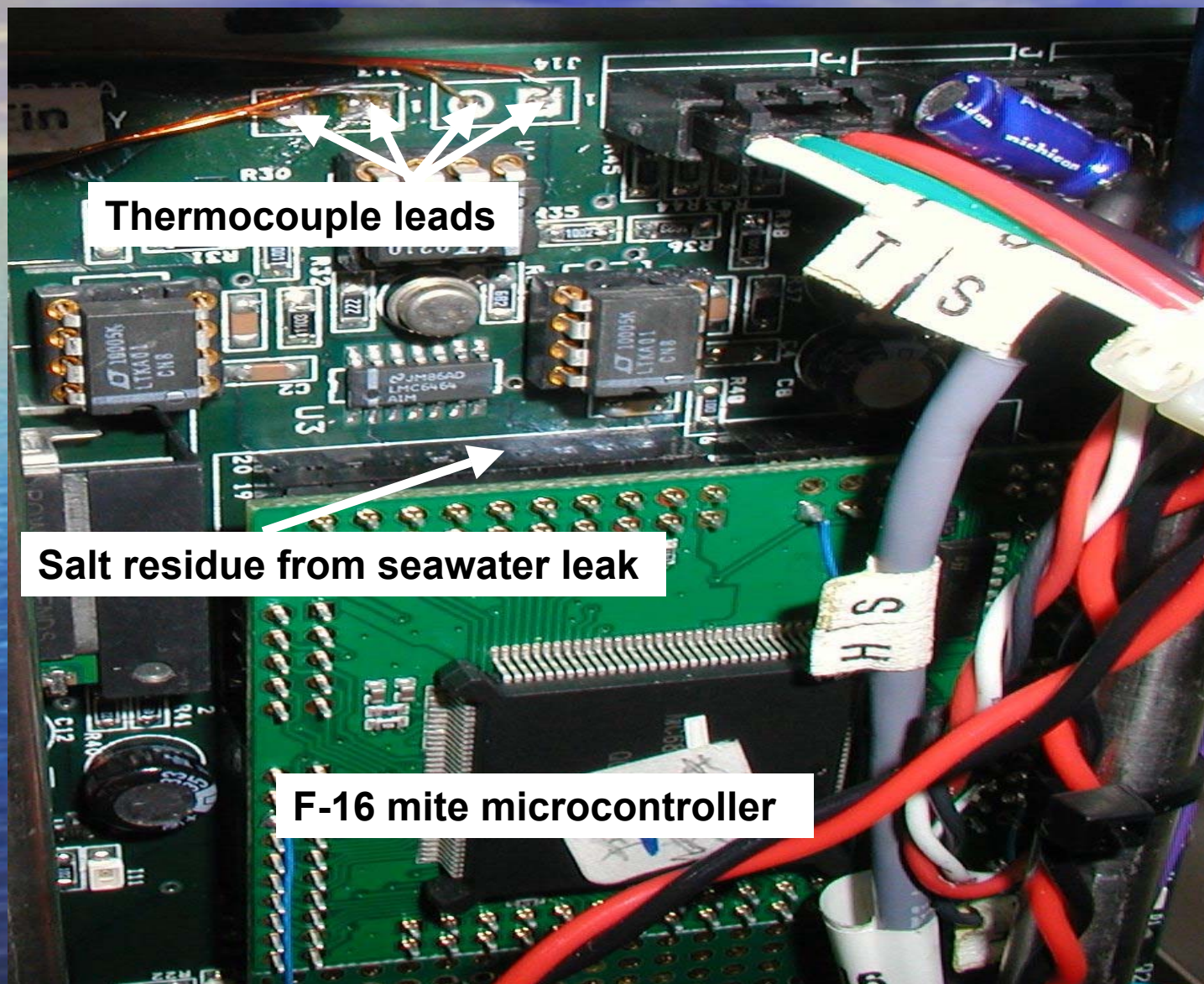

Thermocouple leads

Salt residue from seawater leak

F-16 mite microcontroller

# Hillsborough River, June & July 2005



# Hillsborough River Deployment; June 16 - 18, 2005

## m/z 40 Trace w/ High Pressure Membrane Probe

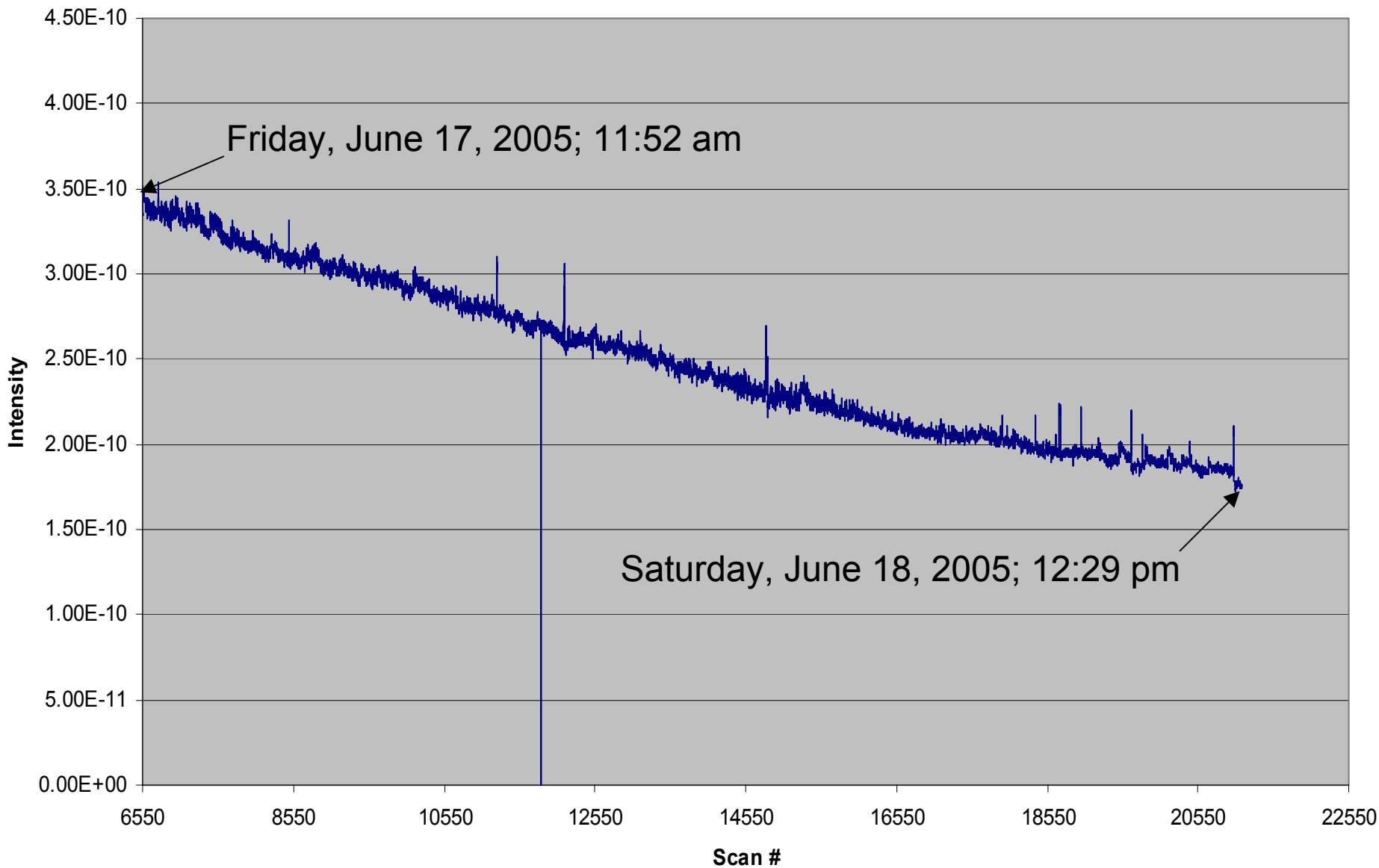

# System modifications to eliminate signal degradation

- Replace flow-over membrane inlet with flow-through inlet
- Cure PDMS at 450<sup>0</sup> F for 4 hours

# Hillsborough River Deployment, July 19 - 21, 2005

## m/z 40 Trace

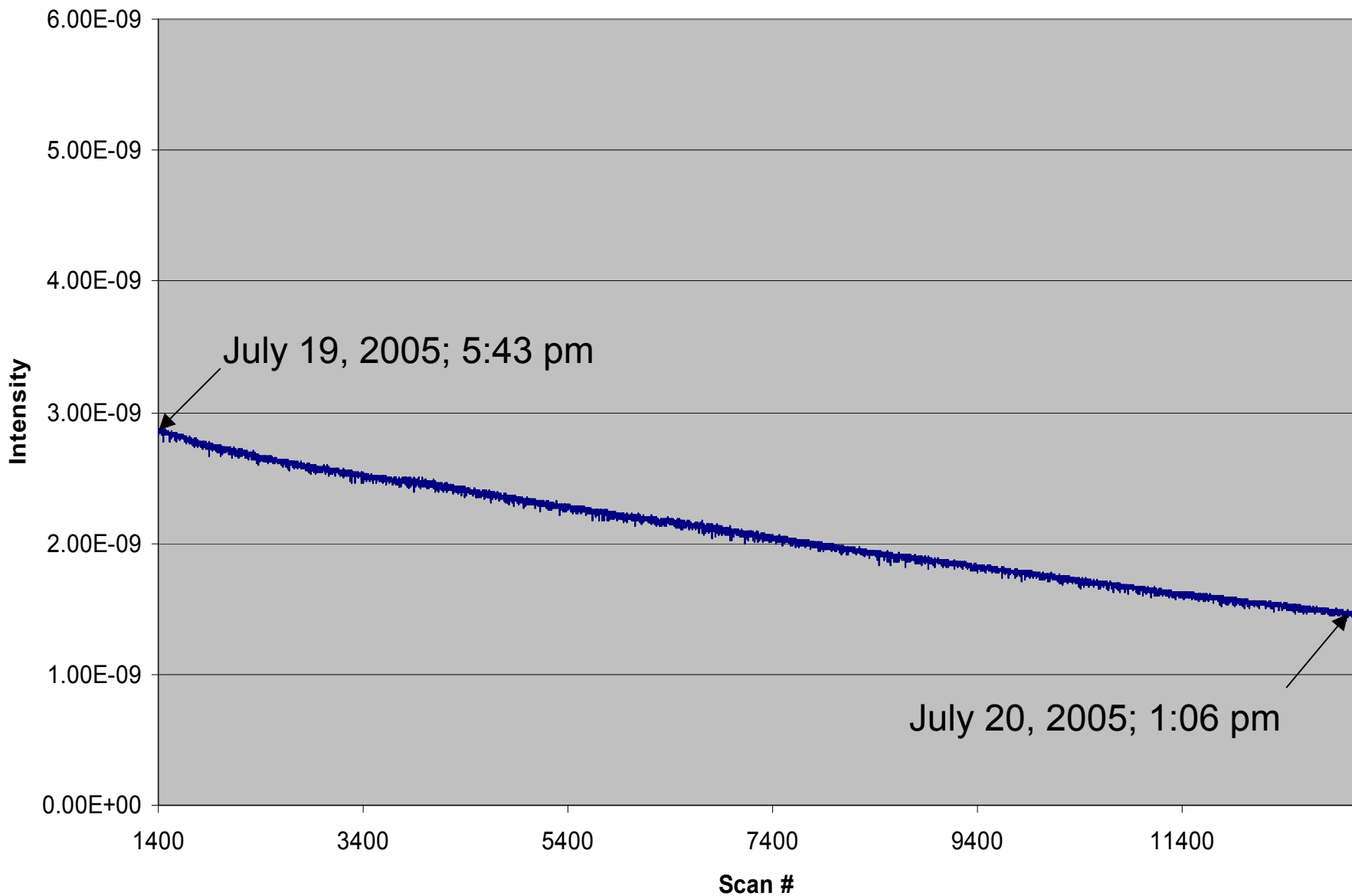



# Calibration

# Calibration - Instrument Parameters

- Physical parameters that effect instrument response:

- Detector settings
- Filament settings
- Membrane construction
- Membrane temperature
- Sample velocity

**Constant during deployment**

- Hydrostatic pressure

**Variable during deployment**

# Calibration - Permeation theory

## Fick's Law

$$\text{Flux} = A \cdot S \cdot D \cdot (dC/dx)$$

Flux  $\propto$  instrument response

A is membrane surface area

S is permeate solubility

D is permeate diffusion rate ( $\text{cm}^2/\text{s}$ )

$dC/dx$  is concentration gradient

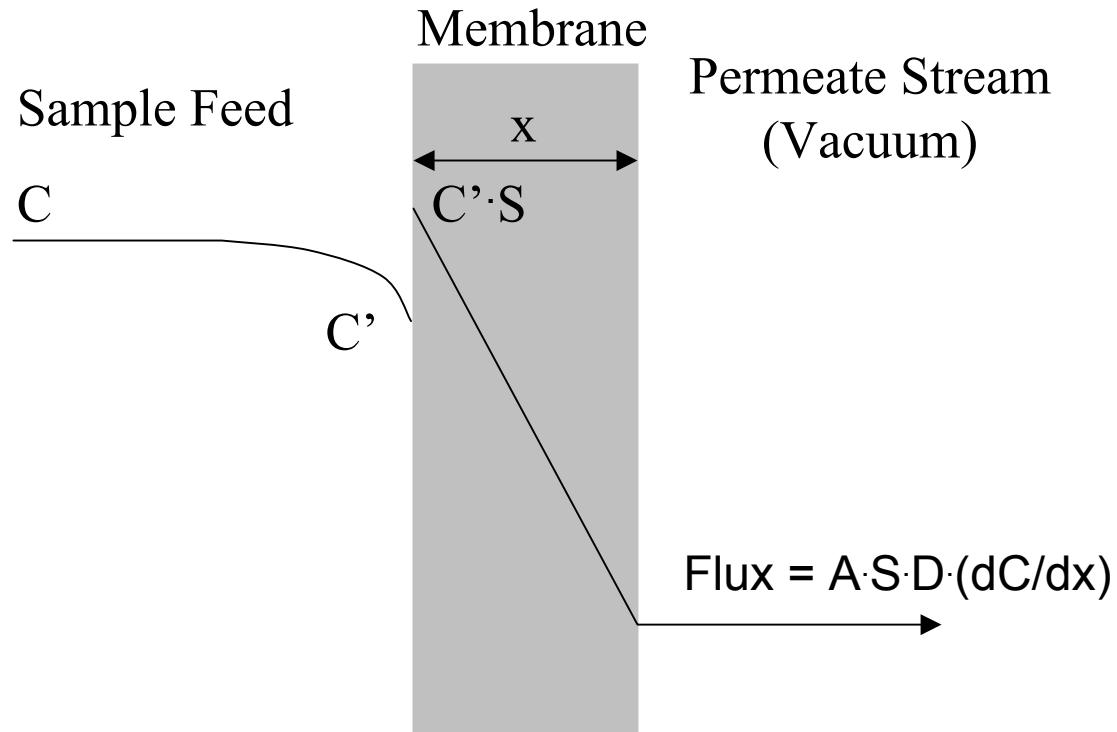

# Normalized Response vs. Temperature

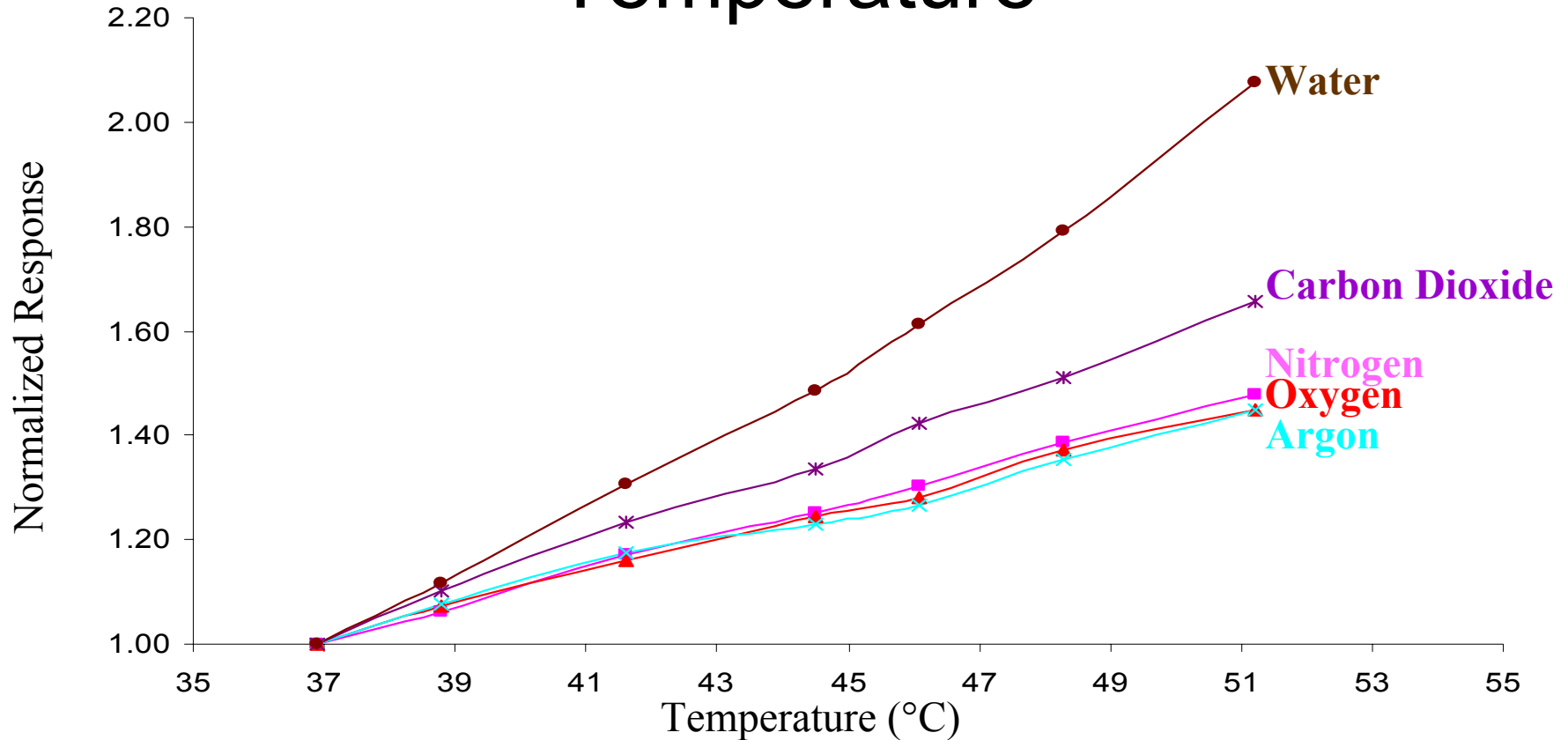

- Approximately linear in our temperature range
- Fixed temperature important for quantification of many analytes

# Normalized Response vs. Sample Velocity

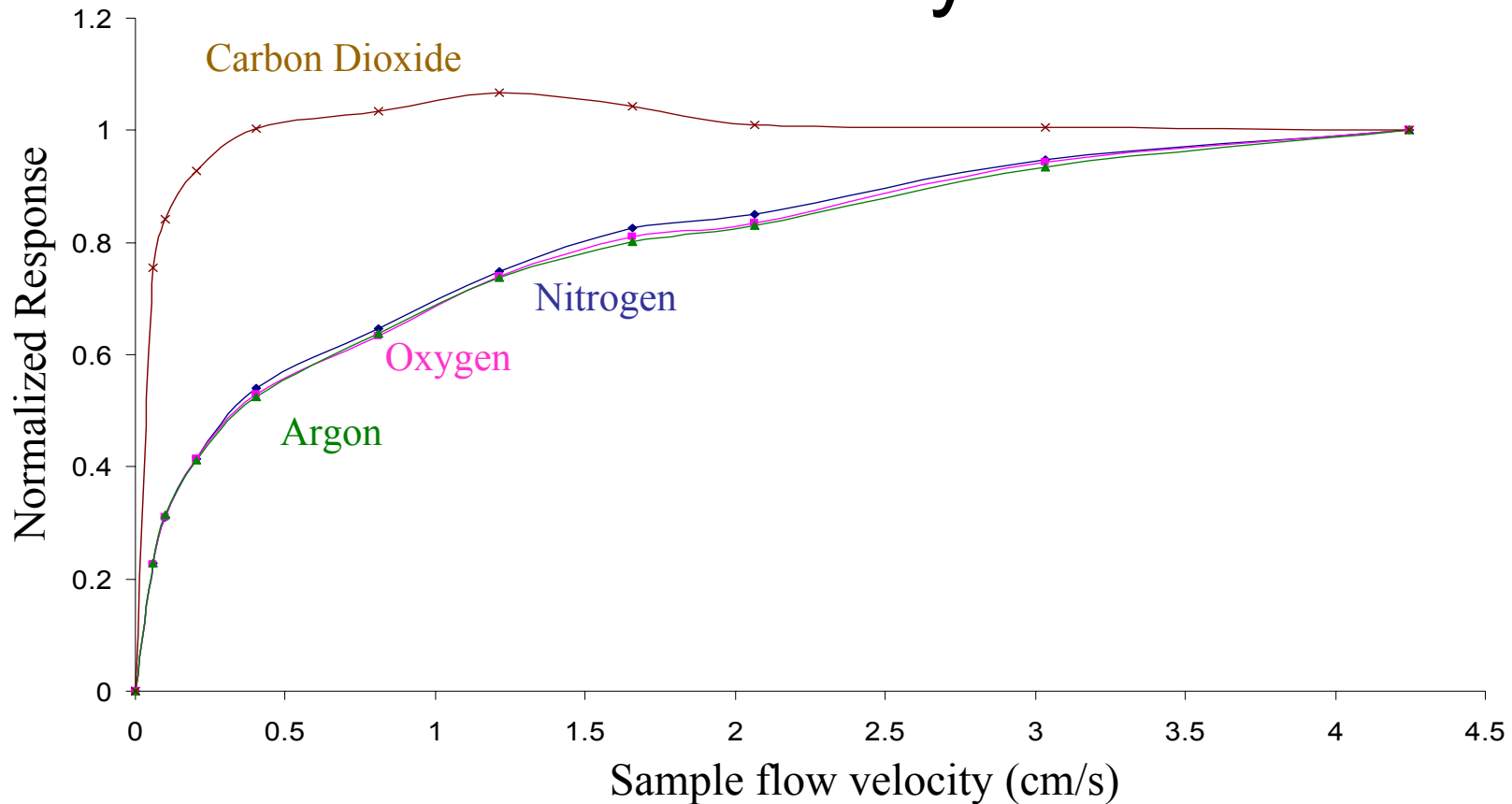

- Strong boundary layer develops at low sample velocities
- Fixed flow velocity important for quantification of many analytes

# Normalized Response vs. Pressure

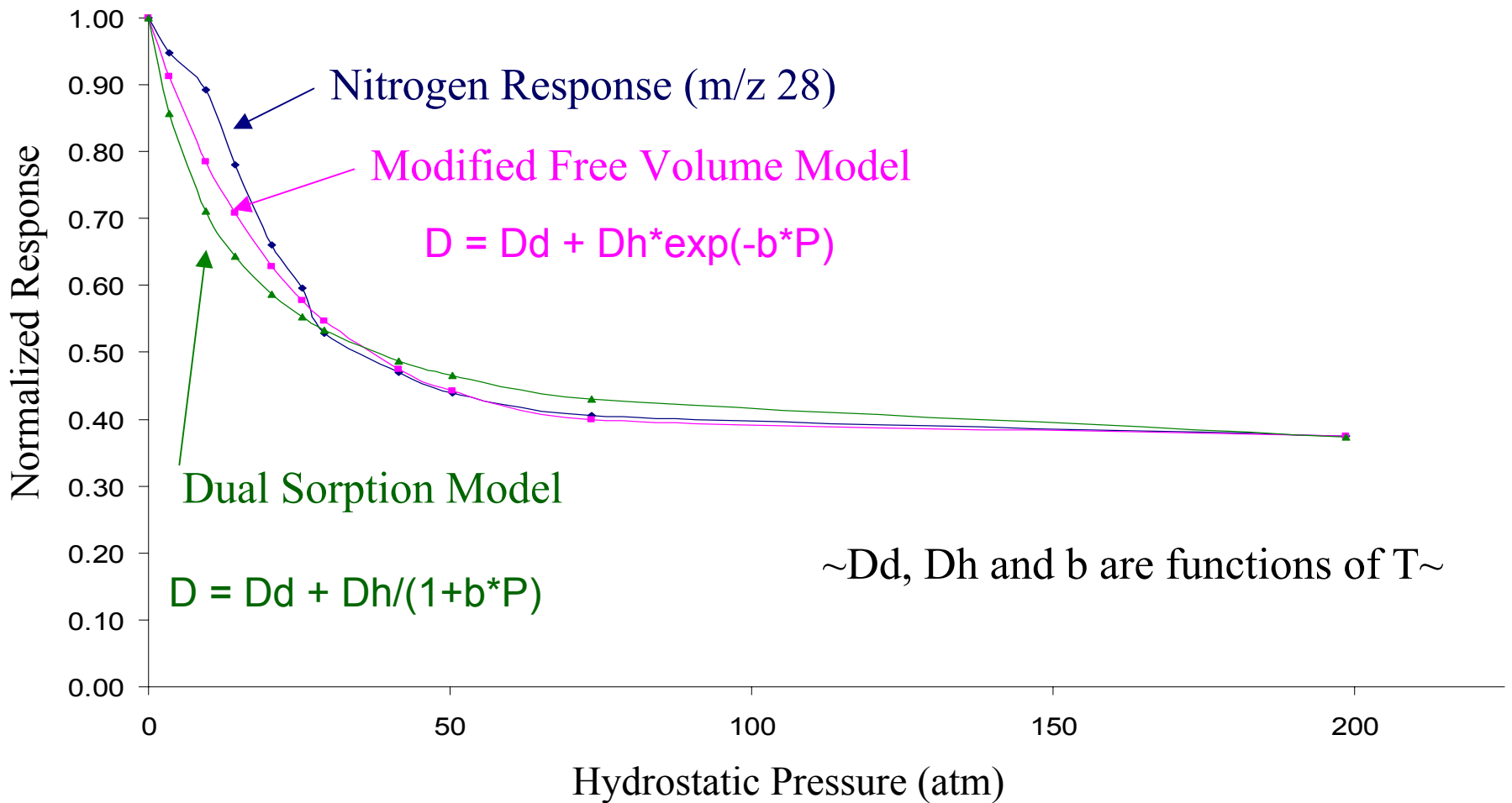

- Strong dependence on pressure, especially more polar compounds
- Not practical fix for pressure; response must be calibrated

# Calibration - Screenshot

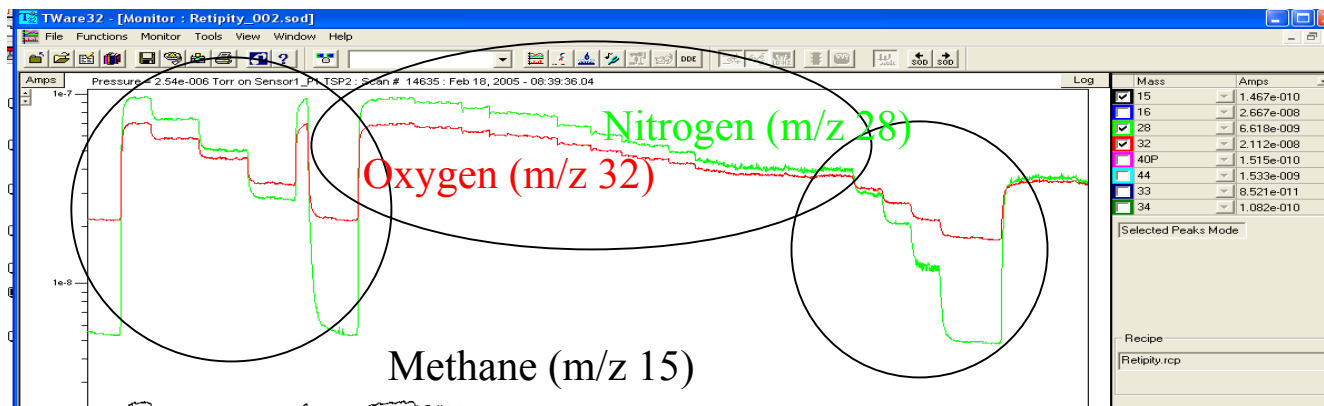

Calibration at 200atm (78% N2, 21% O2, 1% CH4) 2/18/05

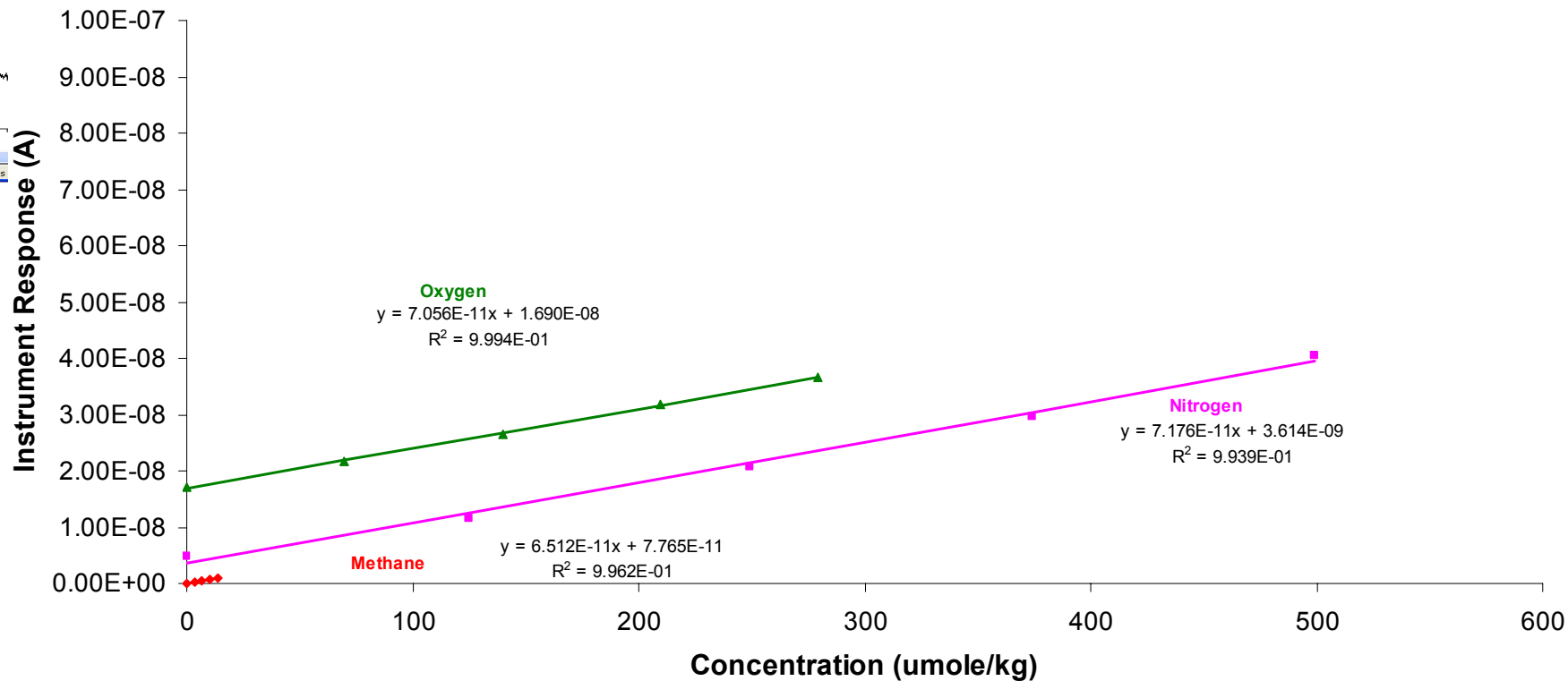



# New Instrument Development

# Next Generation In-Situ Mass Spec

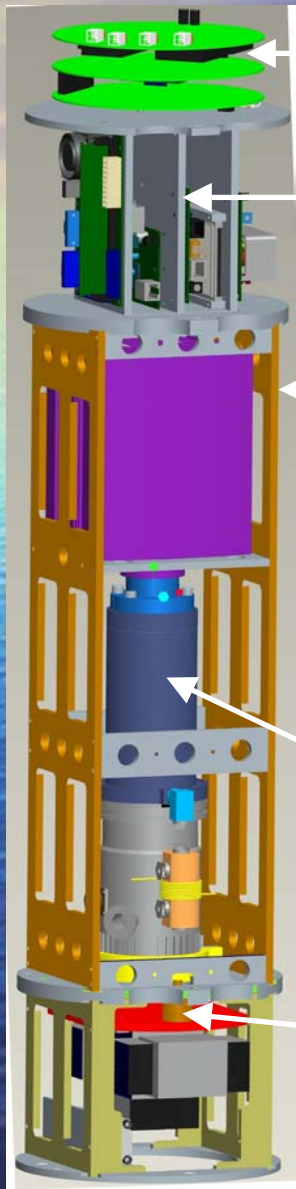

Redesign of microcontroller with expanded capability

Embedded PC upgrade with 1 GHz processor running 170 Mb embedded XP OS

Modular carriage makes for easier disassembly of component systems

Integrated system allows for removal of external pressure vessel without compromising vacuum

Redesigned vacuum chamber with heating jacket allowing for bakeout of chamber

Roughing pump mounted on dampers, reducing noise and vibration

Greenland -- the final frontier.... This is the voyage of Tim and Pete in a kayak. Their 10-day mission: to explore strange new harsh environments, to seek out new challenges and new applications. To boldly go where no mass spectrometrists has gone before.



# Summary

- The in-situ mass spectrometer was successfully deployed to depths of >200 meters in Saanich Inlet
- Gulf of Mexico and Hillsborough River deployments exposed problems and opportunities
- Calibration of mass spec ion intensities with dissolved gas concentrations underway with much yet to be done
- Development of new in-situ mass spec will address shortcomings of present system
- Kayaking in Greenland is fun

# Acknowledgements

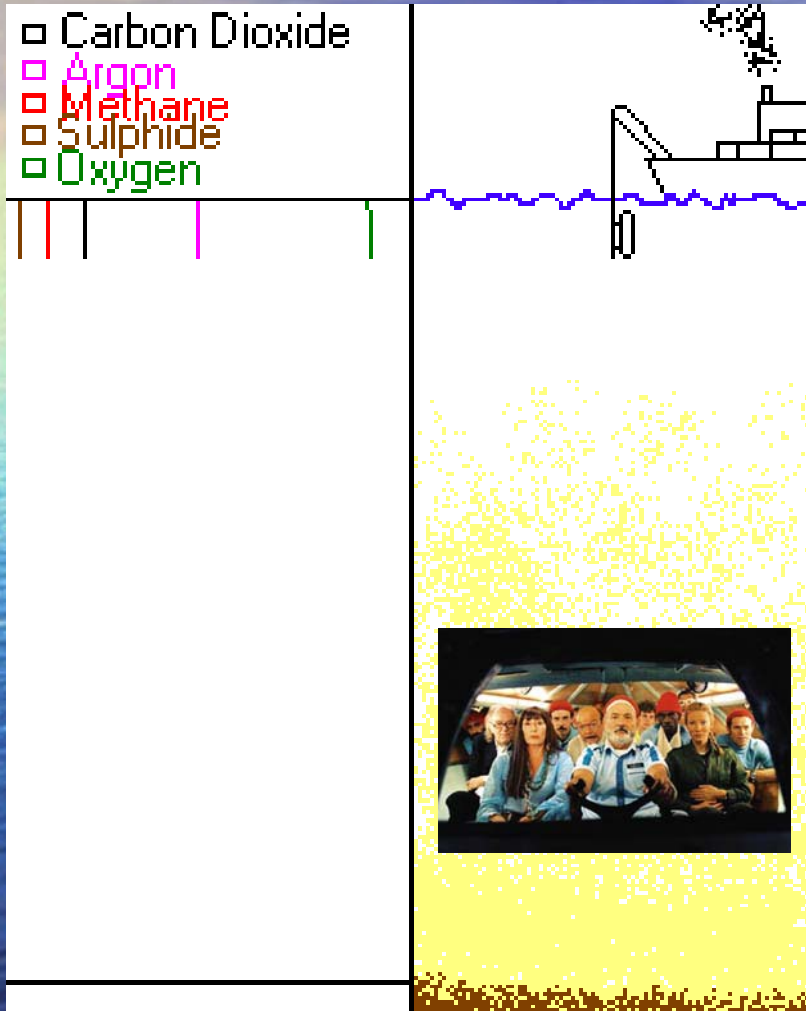

- **David Fries, Gottfried Kibelka, Chad Lembke, Scott Samson, Charlie Cullins, Charlie Jones, Joe Kolesar and Eric Steimle (University of South Florida)**
- **Richard Hildebrand, O. Manuel Uy (Johns Hopkins University, Applied Physics Lab)**
- **Jean Whelan (Woods Hole Oceanographic Institute)**
- **Michael Whitarcar (University of Victoria)**
- **Funding from U.S. Office of Naval Research (ONR) Grant No. N00014-03-1-0479**

